

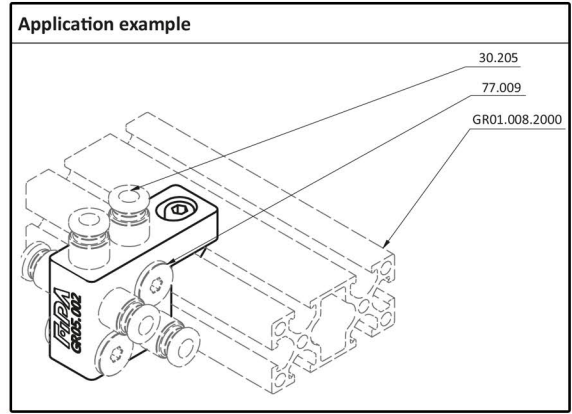

Air and vacuum manifolds



Product notes

> Distribution of air or vacuum in gripper systems

Technical data

Item no.	Suitable for extrusion system	Number of inputs	Number of outputs per input	Total outputs	Shorthand of connections	Connection	Weight [g]	Suitable sealing plugs
GR05.001	SLine / MLine	1	4	4	5	G1/8	31	77.009
GR05.002	SLine / MLine	2	4	8	10	G1/8	49	77.009
GR05.003	SLine / MLine	2	6	12	14	G1/8 (outputs), G1/4 (inputs)	155	77.009 77.008
GR05.004	SLine / MLine	1	8	8	9	G1/8	50	77.009

Dimensions

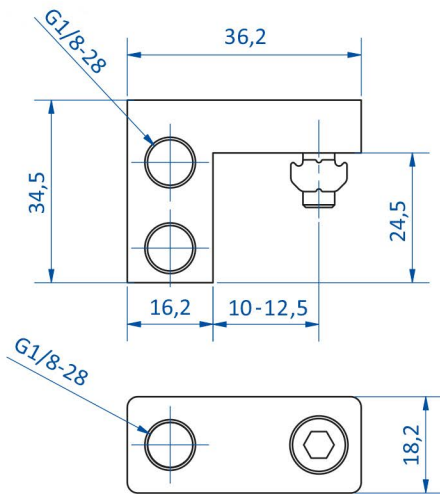

GR05.001

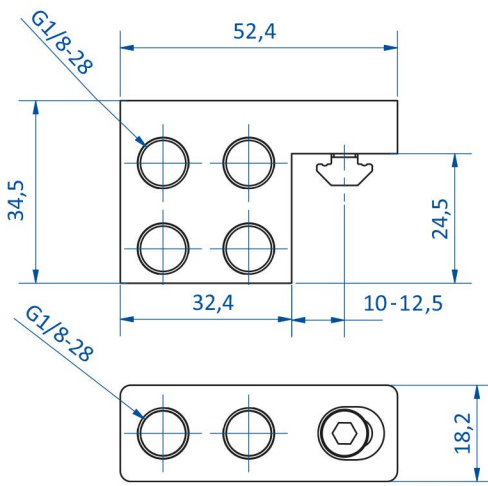

GR05.002

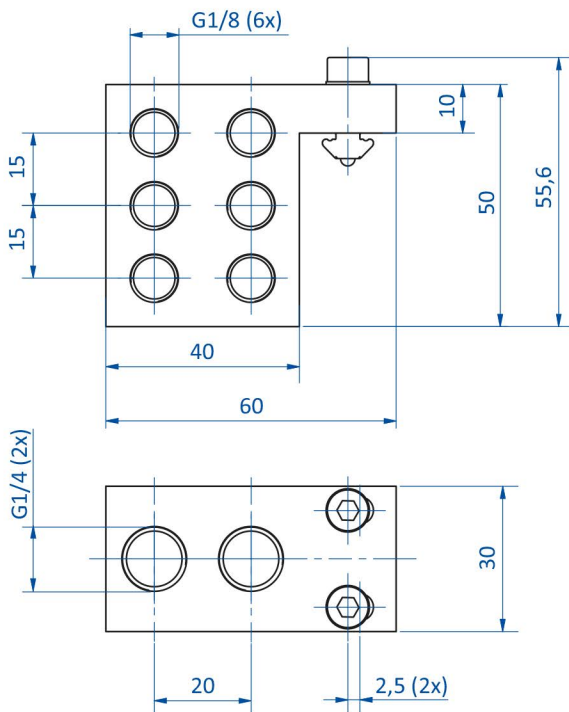

GR05.003

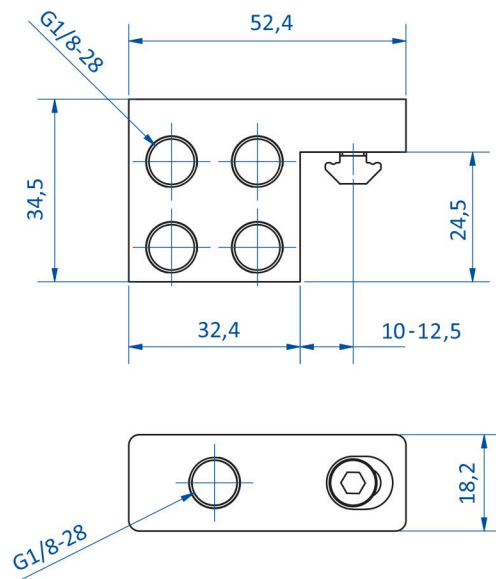

GR05.004