



2-finger angular grippers 40°



Product notes

- > Grippers for undercuts, clamping, mounting and pick & place applications
- > Double-acting: Inside/outside gripping and short duty cycles
- > Body made of high-strength aluminum alloy, jaws are steel
- > Sensors for monitoring gripper action via piston position optionally available
- > Medium: filtered and oiled/unoled air
- > PNP and NPN sensors:
- T-slot (straight) for sensors: GR04.203P, GR04.203N

Technical data

Item no.	GR04.123-10	GR04.123-16	GR04.123-20	GR04.123-25	GR04.123-32
Pressure range [bar (psi)]	1.5 - 7 (21.8 - 101.5)	1.5 - 7 (21.8 - 101.5)	1.5 - 7 (21.8 - 101.5)	1.5 - 7 (21.8 - 101.5)	1.5 - 7 (21.8 - 101.5)
Piston diameter [mm]	10	16	20	25	32
Angle stroke open [°]	-10	-10	-10	-10	-10
Angle stroke closed [°]	30	30	30	30	30
Max. closing torque at 6 bar [Ncm]	11	47	100	199	358
Max. opening torque at 6 bar [Ncm]	15	65	135	252	476
Max. operating frequency [1/min]	80	80	80	80	80
Operating temperature [°C (°F)]	0 - 60 (32 - 140)	0 - 60 (32 - 140)	0 - 60 (32 - 140)	0 - 60 (32 - 140)	0 - 60 (32 - 140)
Weight [g]	100	120	200	330	560
Accessories	Sensor: GR04.203N Sensor: GR04.203P Connector cable: 20.503 Mounting bracket: GR06.050 Base jaw: GR04.123-10-1	Sensor: GR04.203N Sensor: GR04.203P Connector cable: 20.503 Mounting bracket: GR06.051 Base jaw: GR04.123-16-1	Sensor: GR04.203N Sensor: GR04.203P Connector cable: 20.503 Mounting bracket: GR06.052 Base jaw: GR04.123-20-1	Sensor: GR04.203N Sensor: GR04.203P Connector cable: 20.503 Mounting bracket: GR06.053 Base jaw: GR04.123-25-1	Sensor: GR04.203N Sensor: GR04.203P Connector cable: 20.503 Mounting bracket: GR06.054 Base jaw: GR04.123-32-1

Dimensions

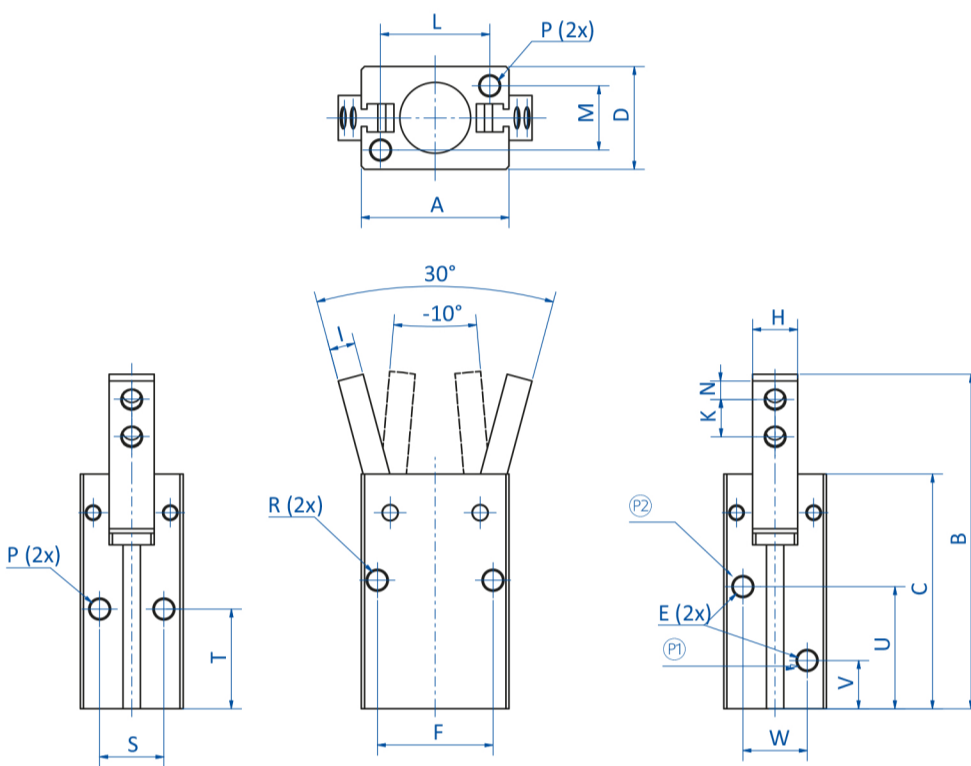

Ⓢ = Sensor slot for GR04.203 Ⓟ = Compressed air supply (open) Ⓠ = Compressed air supply (close)

Item no.	GR04.123-10	GR04.123-16	GR04.123-20	GR04.123-25	GR04.123-32
A [mm]	23	34	45	52	60
B [mm]	52	64	75	89	100
C [mm]	36.5	45.5	53	61	68
D [mm]	16	22	26	32	40
E [mm]	M3	M5	M5	M5	M5
F [mm]	18	24	30	36	44
H [mm]	7	9	12	14	18
I [mm]	4	6	7	9	10
K [mm]	6	8	10	12	14
L [mm]	17	26	35	40	46
M [mm]	10	14	16	20	26
N [mm]	3	3	4	5	6
P	M3	M4	M5	M6	M6
R	M3	M4	M5	M6	M6
S [mm]	10	14	16	20	26
T [mm]	15.5	21	22	24.5	30
U [mm]	19	25.5	28	31	33.5
V [mm]	7.5	7.5	8	9	10
W [mm]	10	12	13	18	24

Diagrams

> Length of gripping point (\* see diagrams)

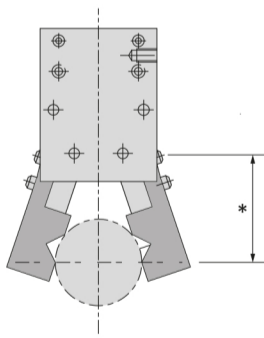

GR04.123-10 | GR04.123-16 | GR04.123-20 | GR04.123-25 | GR04.123-32

> Gripping force as a function of length of gripping point and feed pressure

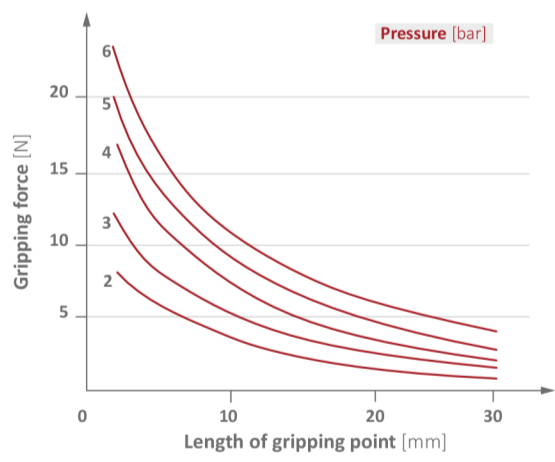

GR04.123-10

> Gripping force as a function of length of gripping point and feed pressure

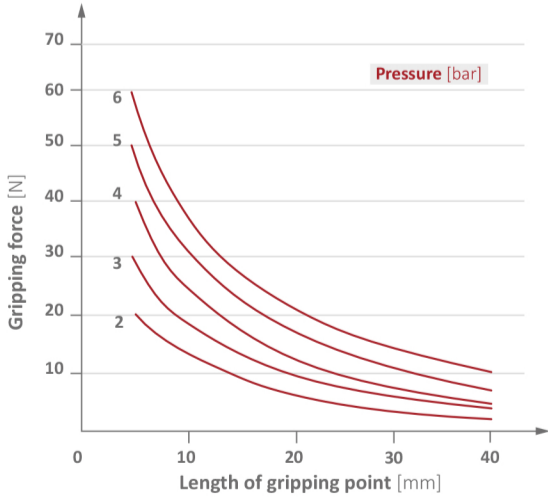

GR04.123-16

> Gripping force as a function of length of gripping point and feed pressure

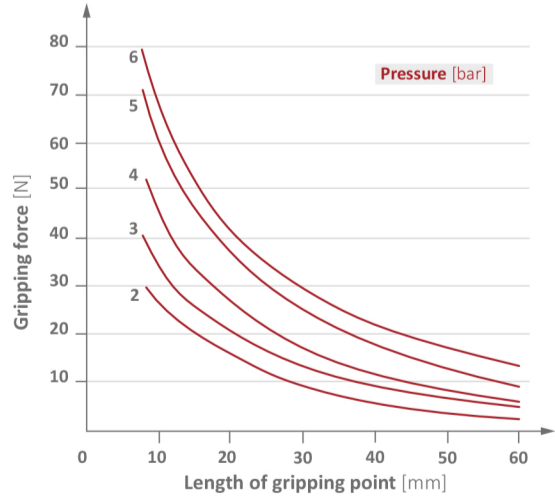

GR04.123-20

> Gripping force as a function of length of gripping point and feed pressure

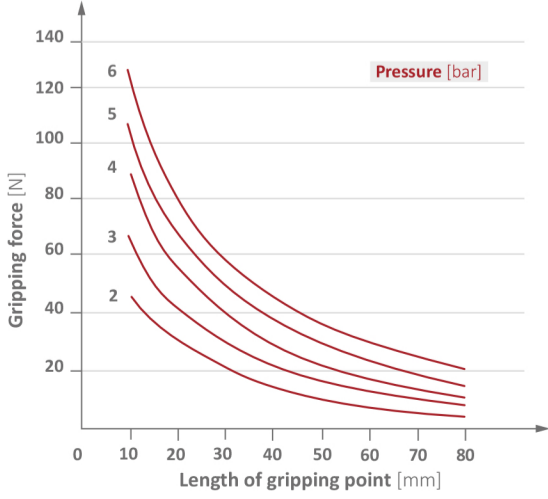

GR04.123-25

> Gripping force as a function of length of gripping point and feed pressure

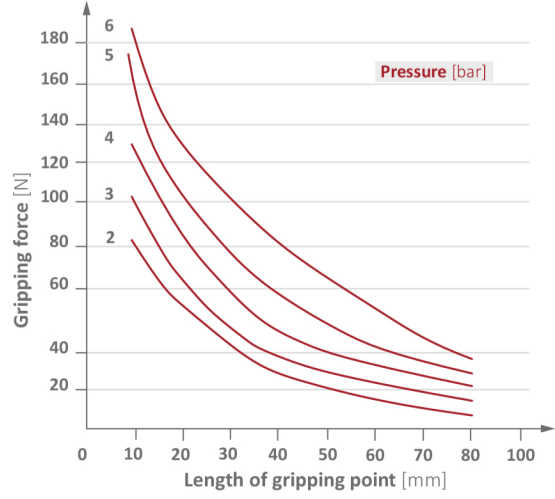

GR04.123-32