



3-finger grippers



Product notes

- > Grippers with high gripping force
- > Compact design
- > Double-acting for inside/outside gripping and short duty cycles
- > Body made of high-strength aluminum alloy, jaws are steel
- > Sensors for monitoring gripper action via piston position optionally available
- > Medium: filtered and oiled/unooled air
- > PNP and NPN sensors:
 - C-slot (straight) for sensors: GR04.198, GR04.198/NPN
 - C-slot (90° angle) for sensors: GR04.202P, GR04.202N
 - C-slot (straight, short design) for sensors: GR04.280P, GR04.280N

Calculation of the inner gripping diameter:

- > Min.: dimensions W closed x 2
- > Max.: dimensions W opened x 2

Technical data

Item no.	GR04.125-16	GR04.125-25	GR04.125-32	GR04.125-40	GR04.125-50	GR04.125-60	GR04.125-80
Operating pressure [bar (psi)]	2 - 6 (29 - 87)	2 - 6 (29 - 87)	1 - 6 (14.5 - 87)	1 - 6 (14.5 - 87)	1 - 6 (14.5 - 87)	1 - 6 (14.5 - 87)	1 - 6 (14.5 - 87)
Piston diameter [mm]	16	25	32	40	50	63	80
Stroke per gripper jaw [mm]	2	3	4	5	6	8	10
Closing force at 5 bar (72.5 psi) [N]	14	42	74	118	187	335	500
Opening force at 5 bar (72.5 psi) [N]	16	47	82	130	204	359	525
Max. operating frequency [1/min]	120	120	60	60	60	60	30
Operating temperature [°C (°F)]	-5 - 70 (23 - 158)	-5 - 70 (23 - 158)	-5 - 70 (23 - 158)	-5 - 70 (23 - 158)	-5 - 70 (23 - 158)	-5 - 70 (23 - 158)	-5 - 70 (23 - 158)
Weight [g]	62	139	240	354	542	1,000	1,850
Accessories	Sensor: GR04.198 GR04.198/NPN GR04.202P GR04.202N GR04.280P GR04.280N Mounting bracket: GR06.125-16	Sensor: GR04.198 GR04.198/NPN GR04.202P GR04.202N GR04.280P GR04.280N Mounting bracket: GR06.125-25	Sensor: GR04.198 GR04.198/NPN GR04.202P GR04.202N GR04.280P GR04.280N Mounting bracket: GR06.125-32	Sensor: GR04.198 GR04.198/NPN GR04.202P GR04.202N GR04.280P GR04.280N Mounting bracket: GR06.125-40	Sensor: GR04.198 GR04.198/NPN GR04.202P GR04.202N GR04.280P GR04.280N Mounting bracket: GR06.125-50	Sensor: GR04.198 GR04.198/NPN GR04.202P GR04.202N GR04.280P GR04.280N Mounting bracket: GR06.125-60	Sensor: GR04.198 GR04.198/NPN GR04.202P GR04.202N GR04.280P GR04.280N Mounting bracket: GR06.125-80

Dimensions

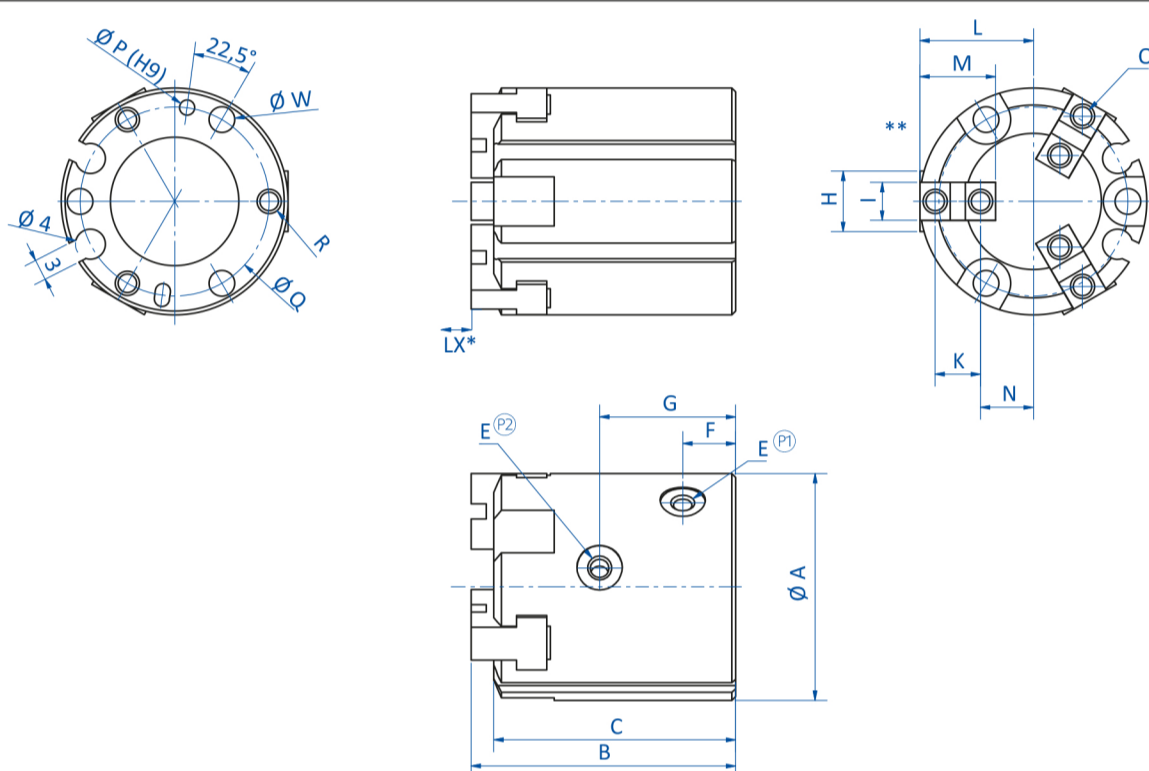

* = LX: Distance between the gripper jaw and the gripper (see gripper force diagrams) P_i = Compressed air supply (open)
 P_c = Compressed air supply (close) P_f = Gripper jaw closed

Item no.	GR04.125-16	GR04.125-25	GR04.125-32	GR04.125-40	GR04.125-50	GR04.125-60	GR04.125-80
A [mm]	30	42	52	62	70	86	106
B [mm]	35	40	44	47	55	66	82
C [mm]	32	37	41	44	52	62	77
E	M3x0.5x11	M5x0.8x15	M5x0.8	M5x0.8	M5x0.8	M5x0.8	G1/8
F [mm]	7	7	8	8	9	12	13.5
G [mm]	18	22	24	26	29	34	40.5
H [mm]	8	12	14	16	18	24	28
I [mm]	5	6	8	8	10	12	14
K [mm]	6	8	11	12	14	17	20
L open [mm]	17	24	32	35	41	51	63.3
L closed [mm]	15	21	28	31	35	43	53.3
M [mm]	10	14	20	21	24	28	32
N open [mm]	9	13	16.5	19	21	28.5	37.3
N closed [mm]	7	9	12.5	14	15	20.5	27.3
O	M3x0.5x5	M3x0.5x5	M4x0.7x8	M4x0.7x8	M5x0.8x10	M5x0.8x10	M6x1x12
P	2x2	3x3	3x3	4x4	4x4	5x5	5x5
Q [mm]	25	34	44	53	62	76	95
R	M3x0.5x4	M4x0.5x7	M4x0.7x6	M5x0.8x0.7	M5x0.8x10	M6x1x9	M6x1x12
W [mm]	3.4	4.5	4.5	5.5	5.5	6.5	6.5

Diagrams

> Gripping force piston diameter 16 mm

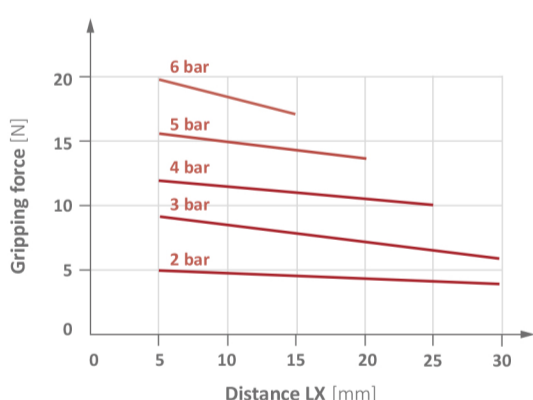

> Gripping force piston diameter 20 mm

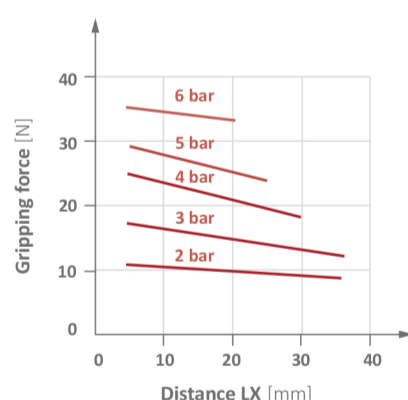

> Gripping force piston diameter 25 mm

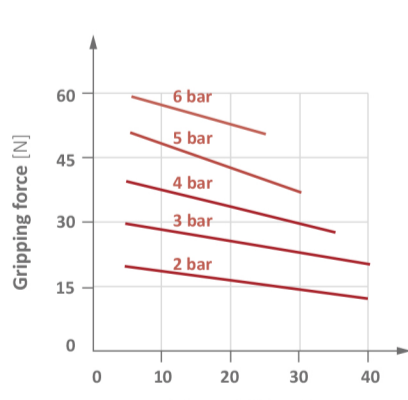

> Gripping force piston diameter 32 mm

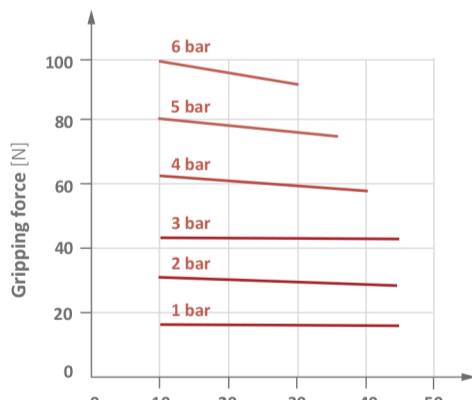

> Gripping force piston diameter 40 mm

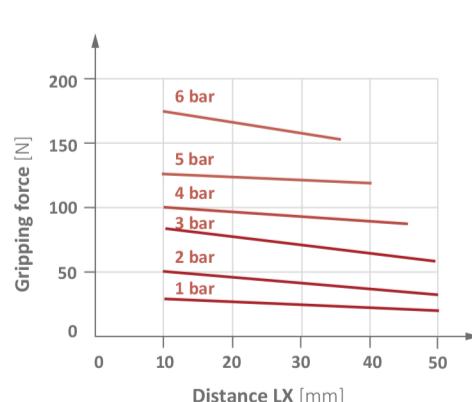

> Gripping force piston diameter 50 mm

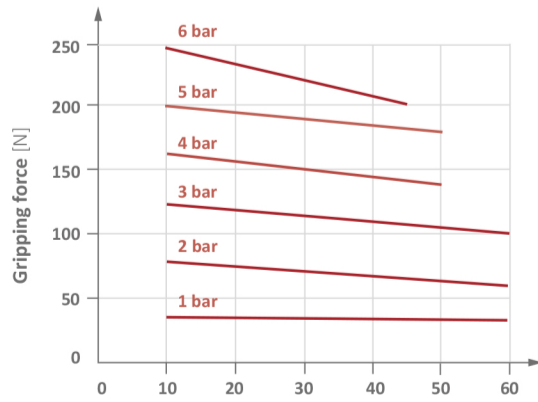

* = LX distance to gripping point

> Gripping force piston diameter 63 mm

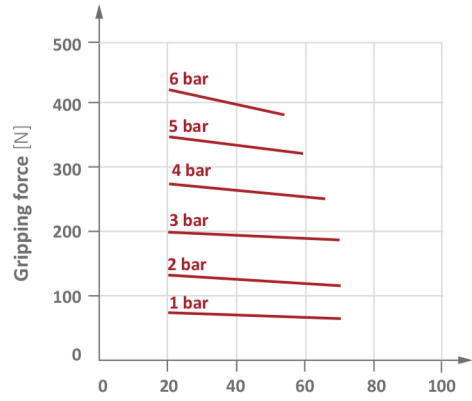

> Gripping force piston diameter 80 mm

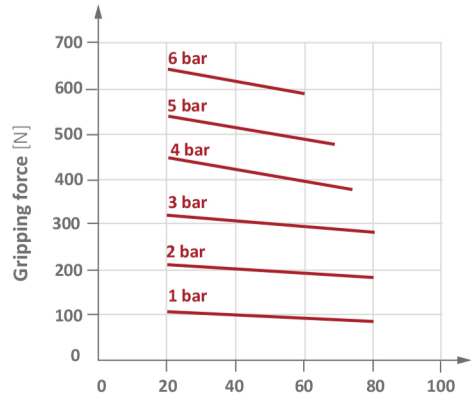

* = LX distance to gripping point