



Nipper technology | Air nippers – stationary

Blades for plastic, for vertical air nippers, straight

Blades for plastic, for vertical air nippers, straight



Product notes

- > Straight blades that can be applied at the right angle to the gate
- > Models with a variety of cutting edges to cover different applications
- > AJ: standard blade
- > AJT: blade extra thin
- > AJL: blade extra long to overcome distance between sprue and nipper
- > AJB: brazed carbide tips for cutting hard plastics or plastics containing fiberglass, increased durability
- > AJH: brazed high-speed steel tip for cutting hard plastic

Technical data

Item no.	Material	Max. cutting thickness [mm]		Weight [g]	Air nippers
		PP/PE	ABS		
NT03AJ	Ferrous alloy	1.5	1	20	GT-NT03
NT03AJT	Ferrous alloy	1.5	1	19	GT-NT03
NE05AJ	Ferrous alloy	2.5	1.5	35	GT-NT05
NT05AJ	Ferrous alloy	2.5	1.5	30	GT-NT05
NT05AJB	Sintered alloy	2.5	1.5	30	GT-NT05
NT05AJH	HSS steel	2.5	1.5	30	GT-NT05
NT05AJL	Ferrous alloy	2.5	1.5	39	GT-NT05
NT05AJT	Ferrous alloy	2.5	1.5	29	GT-NT05
NE10AJ	Ferrous alloy	3.5	2.3	70	GT-NT10
NT10AJ	Ferrous alloy	3.5	2.3	62	GT-NT10
NT10AJB	Sintered alloy	3.5	2.3	76	GT-NT10
NT10AJH	HSS steel	3.5	2.3	76	GT-NT10
NT10AJL	Ferrous alloy	3.5	2.3	62	GT-NT10
NT10AJT	Ferrous alloy	3.5	2.3	65	GT-NT10
NT20AJ	Ferrous alloy	5	3.4	120	GT-NT20
NT20AJB	Ferrous alloy	5	3.4	120	GT-NT20
NT20AJH	HSS steel	5	3.4	120	GT-NT20
NT20AJL	Ferrous alloy	5	3.4	114	GT-NT20



Dimensions

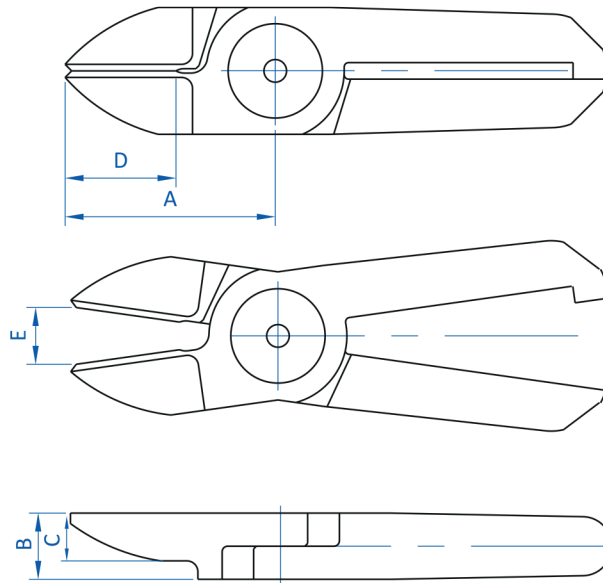

Item no.	A [mm]	B [mm]	C [mm]	D [mm]	E [mm]
NT03AJ	24	7	4	11	3
NT03AJT	24	7	2.3	11	3
NE05AJ	24	7	3.5	12	6
NT05AJ	29	7	5	15	6
NT05AJB	29	7	5	15	6
NT05AJH	29	7	5	15	6
NT05AJL	36	7	5	15	7
NT05AJT	29	7	3	15	6
NE10AJ	27	9	4.5	12	7
NT10AJ	35	9	6	17	7
NT10AJB	35	9	6	17	7
NT10AJH	35	9	6	17	7
NT10AJL	47	9	6	17	9
NT10AJT	35	9	4	17	7
NT20AJ	40	12	6	20	9
NT20AJB	40	12	6	20	9
NT20AJH	40	12	6	20	9
NT20AJL	57	12	6	20	12