



Series | Flat vacuum cups SF

Flat vacuum cups Variopack® – SL-FP

Flat vacuum cups Variopack® – SL-FP

Optimized for FlowPack packaging



EXTREME FLEXIBLE SUCTION LIP



Product notes

Flat vacuum cups with extreme flexible single sealing lip for handling a wide variety of FlowPack packages. Only materials are used who are suitable for the food industry.

Advantage

- > Adapts optimally to a wide variety of surfaces
- > Very high cross force absorption due to internal support structure
- > Quick vacuum cup change by means of plug nipples
- > Increases pick rates and reduces machine downtimes

Technical data

Item no.	Model / Lip dimensions		Material / Color	Hardness [° Shore A]	Connection thread	Accessories
103.030.135.2	SL-FP-30	5	SI (tr)	55	G1/4-female	Spare vacuum cup: 104.030.100.2
103.030.135.2-LE*	SL-FP-30	5	SI-LE (tr)	55	G1/4-female	104.030.100.2-LE*
103.030.135.8	SL-FP-30	5	SI (w)	35	G1/4-female	104.030.100.8
103.030.135.8-LE*	SL-FP-30	5	SI-LE (w)	35	G1/4-female	104.030.100.8-LE*
103.060.133.2	SL-FP-60	10	SI (tr)	55	G3/8-female	104.060.098.2
103.060.133.2-LE*	SL-FP-60	10	SI-LE (tr)	55	G3/8-female	104.060.098.2-LE*
103.060.133.8	SL-FP-60	10	SI (w)	35	G3/8-female	104.060.098.8
103.060.133.8-LE*	SL-FP-60	10	SI-LE (w)	35	G3/8-female	104.060.098.8-LE*

Ordering notes

* For vacuum cups with certificate of conformity for food contact, please select item number ending in "-LE".

Notes:

Vacuum cups made of material with a hardness of 35° Shore A are particularly suitable for thin packaging. The soft, very flexible silicone seals a more extreme drapery than vacuum cups made of 55°. However, the harder version made of SI 55° Shore A can take larger loads.

Dimensions

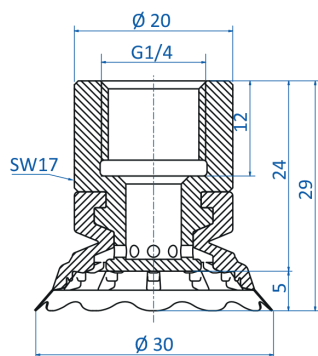

SL-FP-30

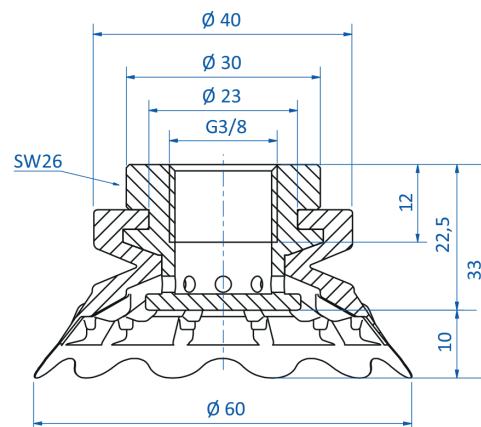

SL-FP-60