



Series | Flat vacuum cups SF

Flat vacuum cups for dynamic handling of oily metal sheets – SM-F

Flat vacuum cups for dynamic handling of oily metal sheets – SM-F



Product notes

Robust, round NBR flat vacuum cups, 60° Shore A with vulcanized fitting made of aluminum and large area, multi-part "anti-slip" cleats. Various connection threads available. PWIS-conform to guideline VDMA 24364 test category A1.

Advantage

- > Reliable, non-slip handling of oily sheets due to "anti-slip" cleats. Good absorption of lateral forces
- > Supports help to prevent deep-drawing or deformation of thin sheets
- > Leak-free suction even with slightly curved surfaces due to flexible sealing lip
- > Vulcanized connection thread ensures a secure fit

Technical Data

Model / Lip dimensions	Thread (Aluminum)						
	G1/4-male	G1/4-female	G3/8-female	M10-male	M14x1.5-male	Rectangular adapter	
SM-F-30	103.030.030.1	103.030.031.1	103.030.032.1	103.030.033.1	103.030.034.1	103.030.035.1	3
SM-F-40	103.040.036.1	103.040.037.1	103.040.038.1	103.040.039.1	103.040.040.1	103.040.041.1	4
SM-F-50	103.050.042.1	103.050.043.1	103.050.044.1	103.050.045.1	103.050.046.1	103.050.047.1	5
SM-F-60	103.060.048.1	103.060.049.1	103.060.050.1	103.060.051.1	103.060.052.1	103.060.053.1	6
SM-F-80	103.080.054.1	103.080.055.1	103.080.056.1	103.080.057.1	103.080.058.1	103.080.059.1	7.6
SM-F-100	103.100.060.1	103.100.061.1	103.100.062.1	103.100.063.1	103.100.064.1	103.100.065.1	9.5
SM-F-125	103.125.066.1	103.125.067.1	103.125.068.1	103.125.069.1	103.125.070.1	103.125.071.1	12.5

Dimensions

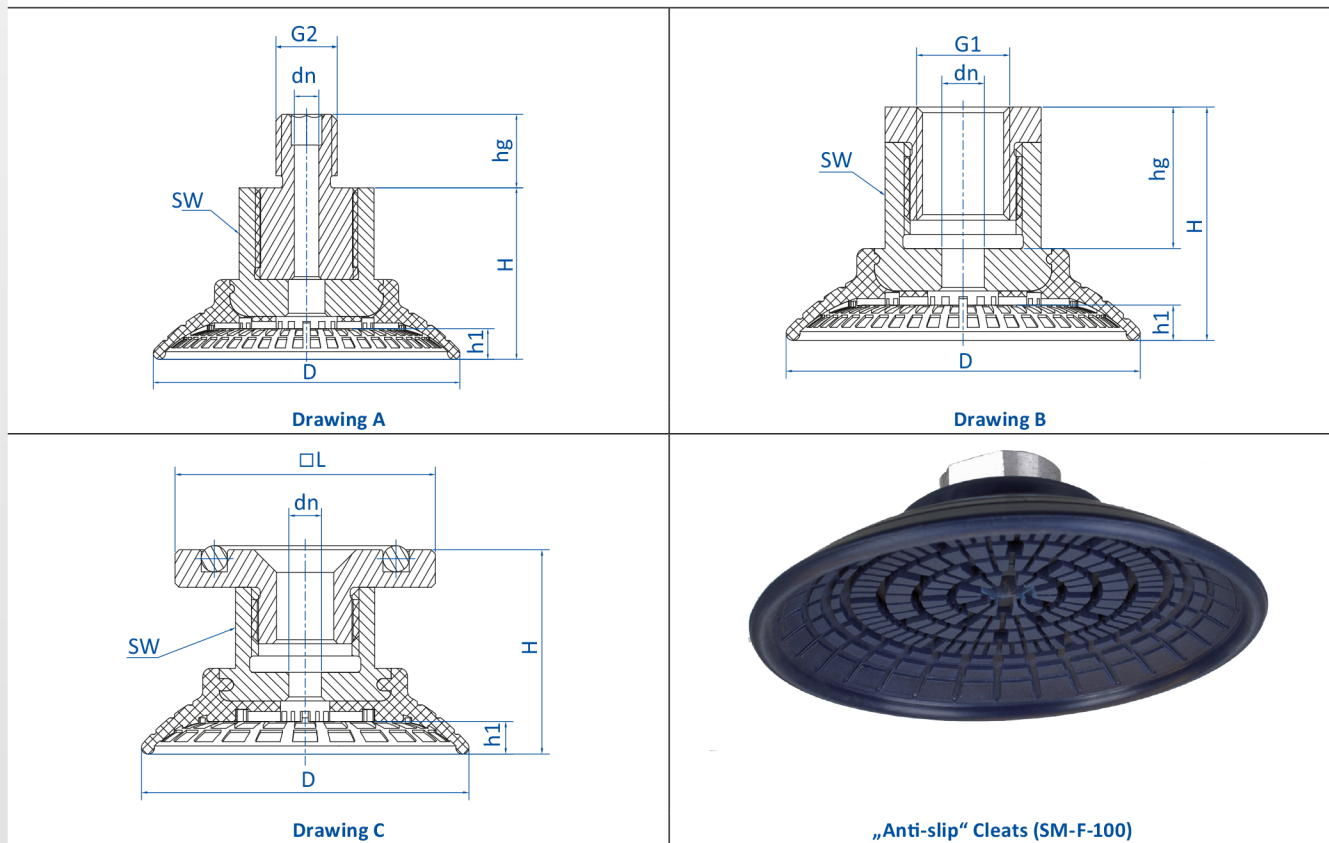

Item no.	Drawing	Ø D [mm]	Ø D max.* [mm]	Ø dn [mm]	G1 (female)	G2 (male)	□L [mm]	H [mm]	h1 [mm]	hg [mm]	SW
103.030.030.1	A	30	32.6	4	--	G1/4	--	20	3	10	17
103.030.031.1	B	30	32.6	4	G1/4	--	--	20	3	12	17
103.030.032.1	B	30	32.6	4	G3/8	--	--	36	3	10	17
103.030.033.1	A	30	32.6	4	--	M10	--	20	3	12	17
103.030.034.1	A	30	32.6	4	--	M14x1.5	--	20	3	12	17
103.030.035.1	C	30	32.6	4	--	--	31.8	23.2	3	--	17
103.040.036.1	A	40	43.1	4	--	G1/4	--	22	4	10	17
103.040.037.1	B	40	43.1	4	G1/4	--	--	22	4	12	17
103.040.038.1	B	40	43.1	4	G3/8	--	--	38	4	10	17
103.040.039.1	A	40	43.1	4	--	M10	--	22	4	12	17
103.040.040.1	A	40	43.1	4	--	M14x1.5	--	22	4	12	17
103.040.041.1	C	40	43.1	4	--	--	31.8	25	4	--	17
103.050.042.1	A	50	53.5	6	--	G1/4	--	28	5	10	22
103.050.043.1	B	50	53.5	6	G1/4	--	--	33	5	20	22
103.050.044.1	B	50	53.5	6	G3/8	--	--	28	5	15	22
103.050.045.1	A	50	53.5	4	--	M10	--	28	5	12	22
103.050.046.1	A	50	53.5	6	--	M14x1.5	--	28	5	12	22
103.050.047.1	C	50	53.5	6	--	--	31.8	27.5	5	--	22
103.060.048.1	A	60	63.8	6	--	G1/4	--	31	6	10	22
103.060.049.1	B	60	63.8	8	G1/4	--	--	36	6	20	22
103.060.050.1	B	60	63.8	8	G3/8	--	--	31	6	15	22
103.060.051.1	A	60	63.8	4	--	M10	--	31	6	12	22
103.060.052.1	A	60	63.8	6	--	M14x1.5	--	31	6	12	22
103.060.053.1	C	60	63.8	8	--	--	31.8	30.5	6	--	22
103.080.054.1	A	80	85.1	6	--	G1/4	--	35	7.6	10	22
103.080.055.1	B	80	85.1	8	G1/4	--	--	40	7.6	20	22
103.080.056.1	B	80	85.1	8	G3/8	--	--	35	7.6	15	22
103.080.057.1	A	80	85.1	4	--	M10	--	35	7.6	12	22
103.080.058.1	A	80	85.1	6	--	M14x1.5	--	35	7.6	12	22
103.080.059.1	C	80	85.1	8	--	--	31.8	34.5	7.6	--	22
103.100.060.1	A	100	104	6	--	G1/4	--	36	9.5	10	22
103.100.061.1	B	100	104	8	G1/4	--	--	41	9.5	20	22
103.100.062.1	B	100	104	8	G3/8	--	--	36	9.5	15	22
103.100.063.1	A	100	104	4	--	M10	--	36	9.5	12	22
103.100.064.1	A	100	104	6	--	M14x1.5	--	36	9.5	12	22
103.100.065.1	C	100	104	8	--	--	31.8	35.5	9.5	--	22
103.125.066.1	A	125	133	6	--	G1/4	--	43	12.5	10	22
103.125.067.1	B	125	133	8	G1/4	--	--	48	12.5	20	22
103.125.068.1	B	125	133	8	G3/8	--	--	43	12.5	15	22
103.125.069.1	A	125	133	4	--	M10	--	43	12.5	12	22
103.125.070.1	A	125	133	6	--	M14x1.5	--	43	12.5	12	22
103.125.071.1	C	125	133	8	--	--	31.8	42.5	12.5	--	22

* aspirated condition