



Series | Oval vacuum cups SO

Oval bellow vacuum cups with 1.5 folds for dynamic handling of oily and dry metal sheets – SM-OB

Oval bellow vacuum cups with 1.5 folds for dynamic handling of oily and dry metal sheets – SM-OB



EXCEPTIONALLY LONG LIFETIME

Product notes

Robust, oval NBR bellows vacuum cups, 60° Shore A with vulcanized fittings made of aluminum.
Large area, multi-part anti-slip cleats.
Various connection threads available.
PWIS-conform to guideline VDMA 24364 test category A1.

Advantage

- > Exceptionally long lifetime – maximizes number of cycles and thus significantly reduces the cost of operation
- > Slip-free handling of oily and dry metal sheets due to anti-slip cleats
- > Good absorption of shear forces
- > Internal supports prevent deep drawing or deformation of thin sheets
- > Leak-free suction even with curved surfaces due to flexible sealing lip
- > Ideally suited for use in constricted spaces
- > Bellow geometry allows handling of three dimensional shaped sheets and ensures good attenuation when placed on a workpiece

Technical data

Model / Lip dimensions	Thread (Aluminium)						
	G1/4-male	G1/4-female	G3/8-female	M10-male	M14x1.5-male	Rectangular adapter	
SM-OB-65x30	138.65x30.023.1	138.65x30.024.1	138.65x30.025.1	138.65x30.026.1	138.65x30.027.1	138.65x30.028.1	7
SM-OB-85x40	138.85x40.029.1	138.85x40.030.1	138.85x40.031.1	138.85x40.032.1	138.85x40.033.1	138.85x40.034.1	9
SM-OB-115x55	138.115x55.035.1	138.115x55.036.1	138.115x55.037.1	138.115x55.038.1	138.115x55.039.1	138.115x55.040.1	13
SM-OB-145x70	138.145x70.041.1	138.145x70.042.1	138.145x70.043.1	138.145x70.044.1	138.145x70.045.1	138.145x70.046.1	16.5

Dimensions

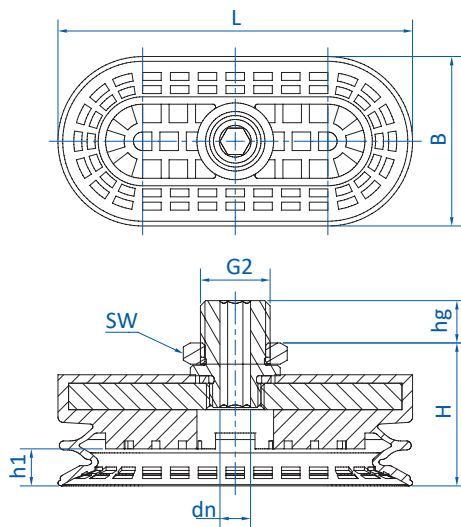

Drawing A

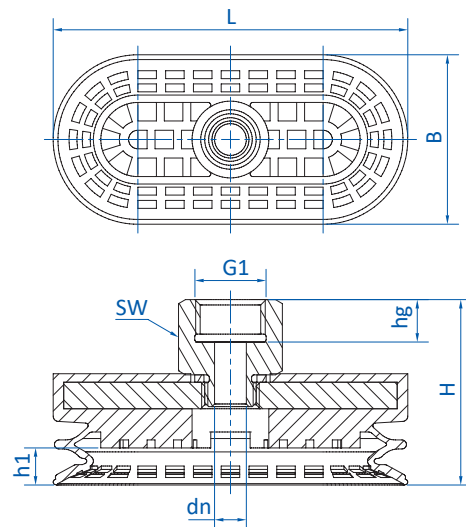

Drawing B



Dimensions

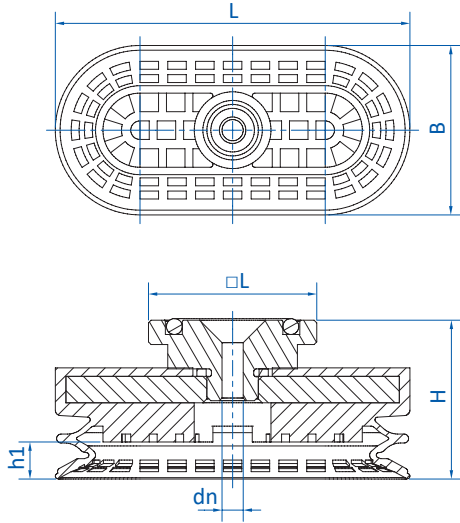

Drawing C

* = Details see "Additional sizes"

Item no.	Drawing	G1 (female)	G2 (male)	L [mm]	L max.* [mm]	B [mm]	B max.* [mm]	dn	□L [mm]	H [mm]	h1 [mm]	hg [mm]	SW
138.65x30.023.1	A	--	G1/4	67	69.3	32	35	SW5	--	27	7	8	17
138.65x30.024.1	B	G1/4	--	67	69.3	32	35	∅ 6 mm	--	35	7	8	17
138.65x30.025.1	B	G3/8	--	67	69.3	32	35	∅ 6 mm	--	35	7	8	22
138.65x30.026.1	A	--	M10	67	69.3	32	35	∅ 5 mm	--	27	7	12	17
138.65x30.027.1	A	--	M14x1.5	67	69.3	32	35	SW5	--	29	7	12	22
138.65x30.028.1	C	--	--	67	69.3	32	35	∅ 4 mm	31.8	30	7	--	--
138.85x40.029.1	A	--	G1/4	87	90	42	46.4	SW5	--	30	9	8	17
138.85x40.030.1	B	G1/4	--	87	90	42	46.4	∅ 6 mm	--	38	9	8	17
138.85x40.031.1	B	G3/8	--	87	90	42	46.4	∅ 6 mm	--	38	9	8	22
138.85x40.032.1	A	--	M10	87	90	42	46.4	SW5	--	30	9	12	17
138.85x40.033.1	A	--	M14x1.5	87	90	42	46.4	SW5	--	32	9	12	22
138.85x40.034.1	C	--	--	87	90	42	46.4	∅ 4 mm	31.8	33	9	--	--
138.115x55.035.1	A	--	G1/4	118	121	57	60	SW6	--	35	13	8	17
138.115x55.036.1	B	G1/4	--	118	121	57	60	∅ 8 mm	--	43	13	8	17
138.115x55.037.1	B	G3/8	--	118	121	57	60	∅ 8 mm	--	43.5	13	9	22
138.115x55.038.1	A	--	M10	118	121	57	60	SW5	--	35	13	12	17
138.115x55.039.1	A	--	M14x1.5	118	121	57	60	SW6	--	37	13	12	22
138.115x55.040.1	C	--	--	118	121	57	60	∅ 6 mm	31.8	38	13	--	--
138.145x70.041.1	A	--	G1/4	148	150	72	77.8	SW6	--	39	16.5	8	17
138.145x70.042.1	B	G1/4	--	148	150	72	77.8	∅ 8 mm	--	47	16.5	8	17
138.145x70.043.1	B	G3/8	--	148	150	72	77.8	∅ 8 mm	--	47.5	16.5	9	22
138.145x70.044.1	A	--	M10	148	150	72	77.8	SW5	--	39	16.5	12	17
138.145x70.045.1	A	--	M14x1.5	148	150	72	77.8	SW6	--	41	16.5	12	22
138.145x70.046.1	C	--	--	148	150	72	77.8	∅ 6 mm	31.8	42	16.5	--	--

* aspirated condition