



Oval vacuum cups, flat, universal – SO-FU



Product notes

Flat vacuum cups in oval design for elongated workpieces where only minimal space is available (e.g. rails, profiles, tubes, bolts, etc.). Size 100x35 mm reinforced with metal inserts. Connection via plug-in nipple.

Advantage

- > Significantly increased suction force compared to round vacuum cups of the same width
- > Soft sealing lip also allows adhesion to curved products
- > Cleats help to prevent warping of the product
- > Cost-effective replacement of worn seals

Ordering notes

From size 15x5 mm upward, a gripper clamp (available separately) is recommended to prevent inadvertent rotation.

Technical data

Item no.	Model / Lip dimensions		Material / Color
132.4x2.001.*	SO-FU-4x2	0.5	NBR (sw), SI (tr), PU (bl)
132.4x2.031.*	SO-FU-4x2A	0.5	NBR (sw), SI (tr), PU (bl)
132.7x4.002.*	SO-FU-7x4	0.8	NBR (sw), SI (tr)
132.7x4.034.*	SO-FU-7x4A	0.8	NBR (sw), SI (tr)
132.12x4.004.*	SO-FU-12x4	0.5	NBR (gr), SI (tr)
132.15x5.008.*	SO-FU-15x5	1	NBR (gr), SI (tr), SI-LE (tr)
132.18x6.012.*	SO-FU-18x6	1	NBR (gr), SI (tr), PU (bl)
132.24x8.016.*	SO-FU-24x8	1	NBR (gr), SI (tr)
132.30x10.018.*	SO-FU-30x10	2	NBR (gr), SI (tr), PU (bl)
132.36x12.019.*	SO-FU-36x12	2	NBR (gr), SI (tr), PU (bl)
132.45x15.020.*	SO-FU-45x15	3	NBR (gr), SI (tr), PU (bl)
132.60x20.022.*	SO-FU-60x20	3	NBR (gr), SI (tr), PU (bl)
132.75x25.023.*	SO-FU-75x25	3	NBR (sw), SI (tr)
132.100x35.26.*	SO-FU-100x35	3	NBR (sw)

Accessories

Clamp

--
--
--
--
--
78.030
78.030
78.032
78.032
78.032
78.033
78.033
78.034
78.034

* Material code: NBR = 1, SI = 2, SI-LE = 2-LE (för Livsmedel/For food Handling), PU = 5



Series | Oval vacuum cups SO

Oval vacuum cups, flat, universal – SO-FU

Accessories

Item no.	Suitable fittings								
	M3-male	M4-male	M5-male	M5-female	M6-male	G1/8-male	G1/8-female	G1/4-male	G1/4-female
132.4x2.001.*	270.011	--	--	--	--	--	--	--	--
132.4x2.031.*	270.014	270.111	270.300	--	--	--	--	--	--
132.7x4.002.*	270.025	--	--	--	--	--	--	--	--
132.7x4.034.*	270.014	270.111	270.300	--	--	--	--	--	--
132.12x4.004.*	--	--	270.134	270.347	270.104	270.033	270.478	--	--
132.15x5.008.*	--	--	270.094	270.005	--	270.095	270.096	--	--
132.18x6.012.*	--	--	270.094	270.005	--	270.095	270.096	--	--
132.24x8.016.*	--	--	270.094	270.005	--	270.095	270.096	--	--
132.30x10.018.*	--	--	270.094	270.005	--	270.095	270.096	--	--
132.36x12.019.*	--	--	270.094	270.005	--	270.095	270.096	--	--
132.45x15.020.*	--	--	--	--	--	--	--	270.097	270.098
132.60x20.022.*	--	--	--	--	--	--	--	270.097	270.098
132.75x25.023.*	--	--	--	--	--	--	--	270.097	270.098
132.100x35.26.*	--	--	--	--	--	--	--	270.097	270.098

Dimensions

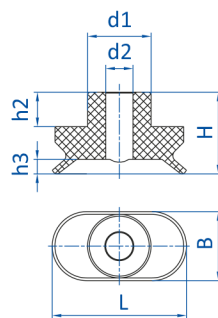

Drawing A

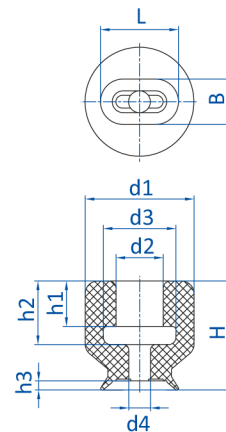

Drawing B

* Material code: NBR = 1, SI = 2, SI-LE = 2-LE (för Livsmedel/For food Handling), PU = 5



Dimensions

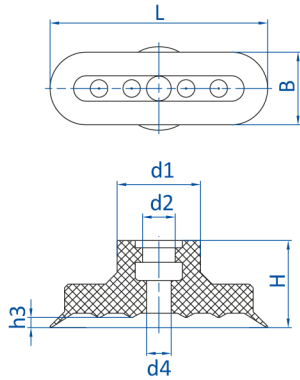

Drawing C

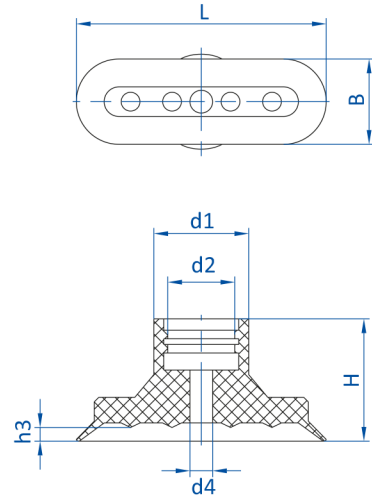

Drawing D

Item no.	Drawing	L [mm]	B [mm]	Ø d1 [mm]	Ø d2 [mm]	Ø d3 [mm]	Ø d4 [mm]	H [mm]	h1 [mm]	h2 [mm]	h3 [mm]
132.4x2.001._*	A	5	2.7	2	1	--	--	3	--	1.3	0.5
132.4x2.031._*	B	4.3	2.5	6	2.6	4	1	6	2.5	3.5	0.5
132.7x4.002._*	A	7.5	3.8	3.5	1.5	--	--	4.5	--	1.9	0.8
132.7x4.034._*	B	7.5	4	6	2.4	3	1.4	6	2.3	3	0.7
132.12x4.004._*	B	12	4	8	4	--	1.5	15	--	9.5	1
132.15x5.008._*	C	15	5	9	5	--	2	12	--	--	0.8
132.18x6.012._*	C	18	6	9	4.5	--	2	12	--	--	1.3
132.24x8.016._*	C	24	8	11.5	4.5	--	3	12	--	--	1.3
132.30x10.018._*	C	30	10	11.5	4.5	--	3.4	12	--	--	1.4
132.36x12.019._*	C	36	12	12	5	--	4	12	--	--	1.2
132.45x15.020._*	D	44	15	16.5	12	--	4	22	--	--	2.4
132.60x20.022._*	D	60	20	16.5	11.5	--	4	22	--	--	2.2
132.75x25.023._*	D	75	25	17.5	11	--	3.5	22	--	--	3
132.100x35.26._*	D	100	35	17.5	11.5	--	8	22	--	--	3.1

* Material code: NBR = 1, SI = 2, SI-LE = 2-LE (för Livsmedel/For food Handling), PU = 5