



Series | Bellows vacuum cups SB

Monoflex bellows cups, 1.5 folds – SP-BX1

Monoflex bellows cups, 1.5 folds – SP-BX1



Product notes	Advantage
Bellows vacuum cup with 1.5 folds made of very wear-resistant polyurethane. Hardness 50° Shore A Support ribs stabilize the product.	<ul style="list-style-type: none"> > Long life cycle reduces machine downtimes > Oil and ozone-resistant > Bellows compensate for height and angle differences > Cleats allow for fast acceleration

Notes:

Explanation of the type description:
 > SP-BX1 = Series name of the bellows vacuum cup with 1.5 folds
 > -xx = nominal diameter
 > -PUxx = Material / Hardness
 Example: SP-BX1-15-PU50 = bellows vacuum cup with 1.5 folds and a nominal diameter of 15 mm, material Polyurethan 50° Shore A

Technical data

Model / Lip dimensions	Connection thread					Spare cup
	M5-male	M6-male	G1/8-male	G1/8-female		
SP-BX1-10-PU50	22.011.332.22	22.011.333.22	--	--	3	23.011.294.22
SP-BX1-15-PU50	22.016.253.22	22.016.254.22	--	--	4,5	23.016.263.22
SP-BX1-20-PU50	--	--	22.021.255.22	--	5	23.021.264.22
SP-BX1-25-PU50	--	--	22.026.256.22	--	5	23.026.265.22
SP-BX1-35-PU50	--	--	--	22.037.257.22	9	23.037.266.22
SP-BX1-50-PU50	--	--	--	22.053.259.22	10	23.053.267.22

Model / Lip dimensions	Connection thread					Spare cup
	G1/4-male	G3/8-male	G3/8-female	G1/2-female		
SP-BX1-35-PU50	22.037.258.22	--	--	--	9	23.037.266.22
SP-BX1-50-PU50	22.053.260.22	22.053.261.22	--	--	10	23.053.267.22
SP-BX1-75-PU50	--	22.075.262.22	22.075.263.22	--	18	--

Dimensions

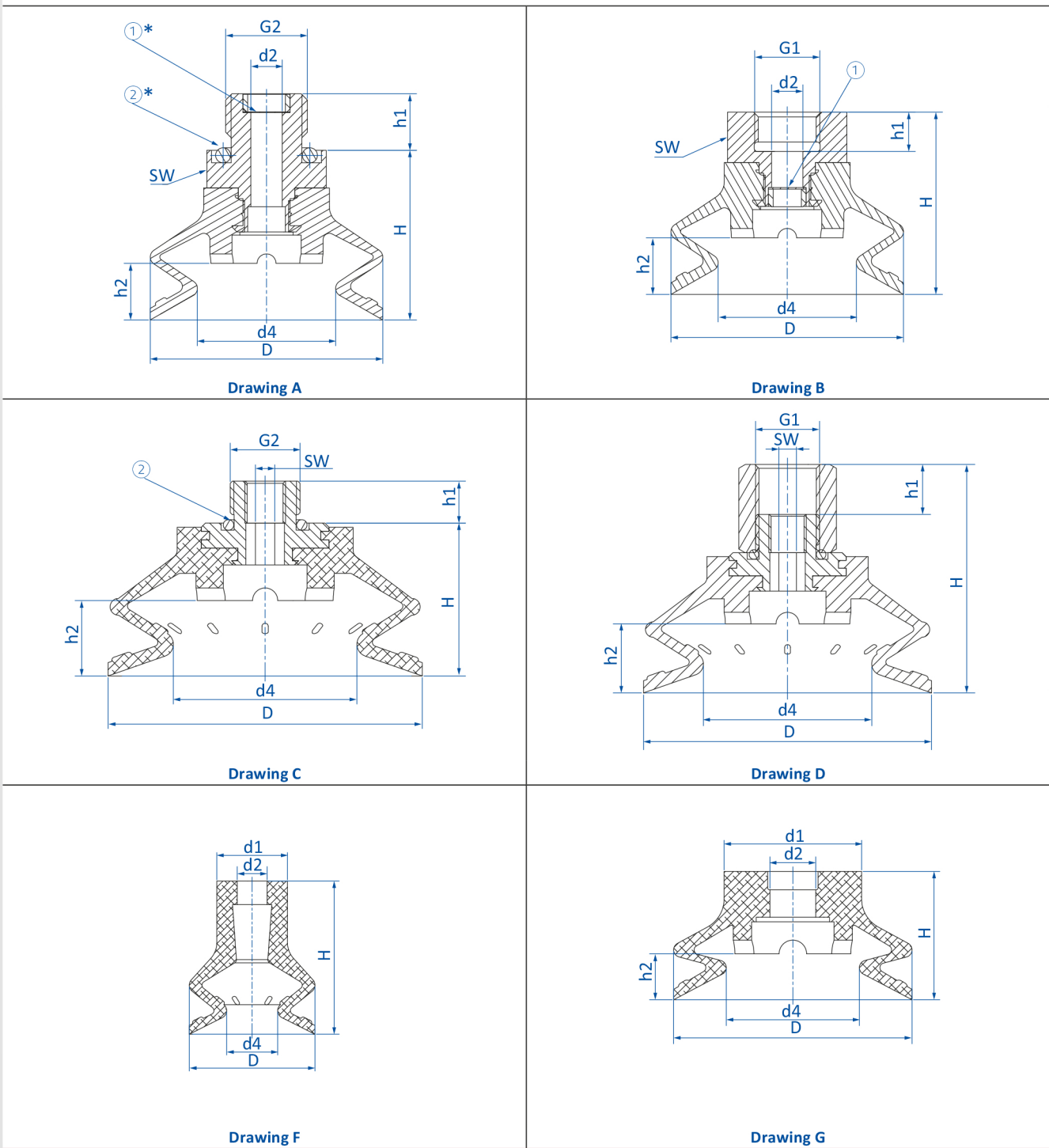

① = Filter screen ② = O-Ring * = Size 11 and 16 mm without strainer and O-ring

Item no.	Drawing	Ø D [mm]	Ø d1 [mm]	Ø d2 [mm]	Ø d4 [mm]	Ø d3 [mm]	G1 (female)	G2 (male)	H	h1 [mm]	h2 [mm]	SW
22.011.332.22	A	11	--	2.8	5.6	14	--	M5	17.5	5	--	8
22.011.333.22	A	11	--	2.5	5.6	14	--	M6	18	6	--	13
22.016.253.22	A	16	--	2.5	6.5	14	--	M5	25	3.6	--	8
22.016.254.22	A	16	--	2.5	6.5	14	--	M6	24	6	--	13
22.021.255.22	A	21	--	4	12	14	--	G1/8	19	7	5	13
22.026.256.22	A	26	--	4	14.5	14	--	G1/8	19	7	5	13
22.037.257.22	B	37	--	5	22	14	G1/8	--	29	6.3	9	19
22.037.258.22	A	37	--	5	22	14	--	G1/4	27	9	9	19
22.053.259.22	B	53	--	8	32.5	14	G1/8	--	35	9	10	22
22.053.260.22	A	53	--	6	32.5	14	--	G1/4	32	9	10	22
22.053.261.22	A	53	--	6	32.5	14	--	G3/8	32	10	10	22
22.075.262.22	C	75	--	--	44	14	--	G3/8	36.5	10	18	8
22.075.263.22	D	75	--	--	44	14	G3/8	--	59.5	13	18	8
23.011.294.22	F	11	9	3.8	5.6	14	--	--	14	--	--	--
23.016.263.22	F	16	9	4	6.5	14	--	--	19.5	--	--	--
23.021.264.22	G	21	11	5	12	14	--	--	14	--	5	--
23.026.265.22	G	26	15	5	14.5	14	--	--	14	--	5	--
23.037.266.22	G	37	20	7	22	14	--	--	21	--	9	--
23.053.267.22	G	53	26	10.5	32.5	14	--	--	26	--	10	--