



Extrusion systems | Special elements

Pneumatic centering units, single acting

Pneumatic centering units, single acting



STRONG HOLDING FORCE

Product notes

- > Single-acting centering element for docking with the mold
- > Use for locking the gripper in place while placing inserts or demolding with high force
- > Optional Sensors can be used to detect locking and/or unlocking
- > Bushing can be mounted from either side in the mold

Technical data

Item no.	Suitable guiding sleeve	Clamping \varnothing [mm]	Holding force at 6 bar (87 psi) [N]	Accessories
GR07.520-14	GR07.521-14	14	400	Sensor: GR04.198 Sensor: GR04.198/NPN Sensor mounting bracket: GR04.038S
GR07.520	GR07.521	20	750	Sensor: GR04.198 Sensor: GR04.198/NPN Sensor mounting bracket: GR07.520S

Dimensions

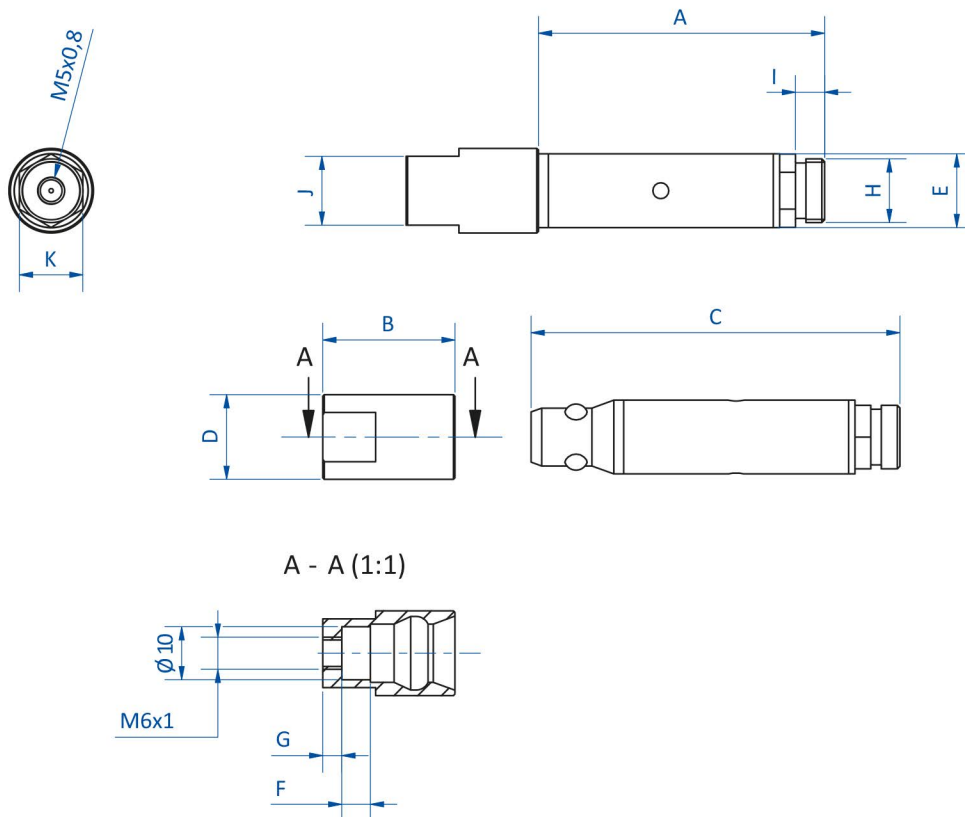

Item no.	Guiding sleeve	A [mm]	B [mm]	C [mm]	$\varnothing D$ [mm]	E [mm]	F [mm]	G [mm]	H	I [mm]	J [mm]	K [mm]
GR07.520-14	GR07.521-14	54	25	70	16	14	5.4	4	M12x1	5.5	13	12
GR07.520	GR07.521	75	33	96	26	20	5.4	4.6	M17x1	8	--	17