

DOUBLE EJECTION

ES Doble Expulsión DE Zweistufenauswerfer
 IT Doppia Espulsione PT Dupla Extracção FR Double Ejection



DE

EJECTION

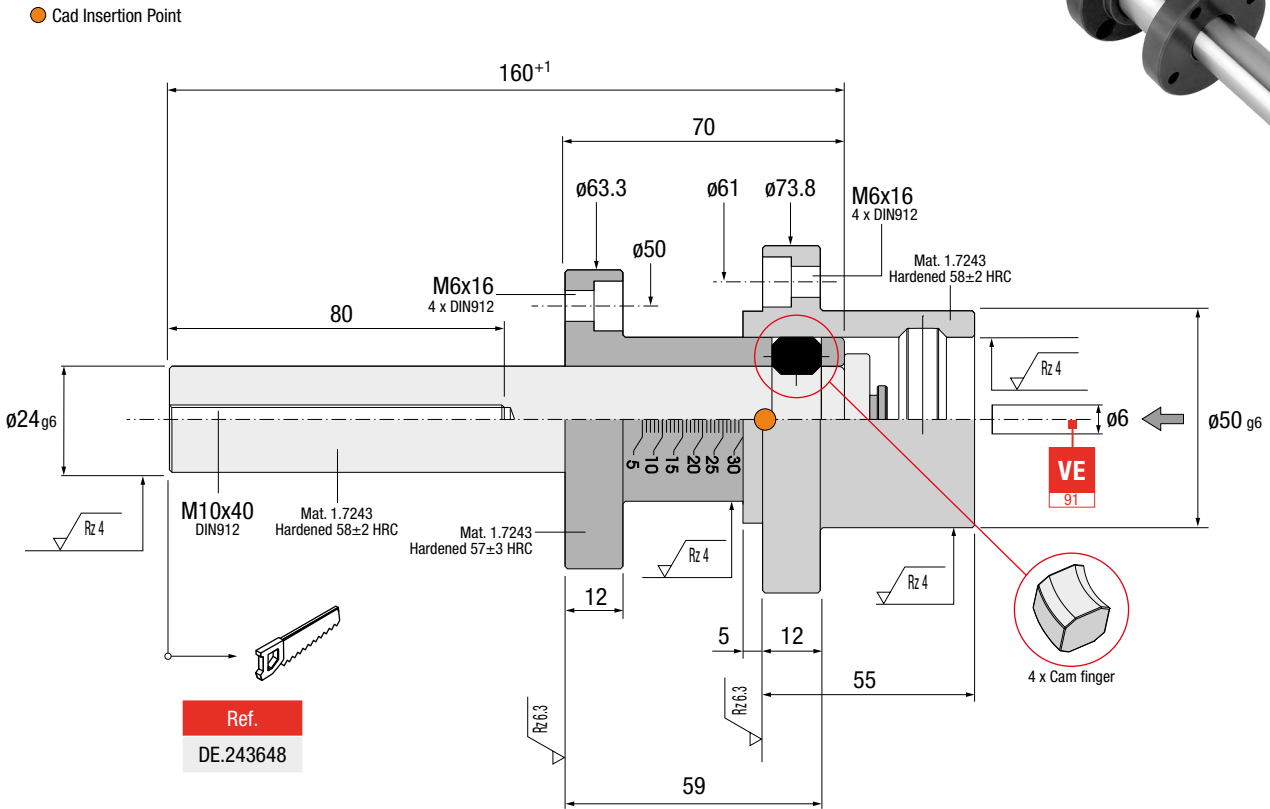

Ref.
DE.243648

IMPORTANT !
 Use the scale from 0 to 30mm, to select the first stroke.
 Seleccionar el primer recorrido mediante la regulación de 0 a 30 mm.
 Um den 1. Hub festzulegen, die Einteilung von 0 - 30 mm.
 Selezionare la prima corsa mediante la regolazione da 0 a 30mm.
 Seleccionar o primeiro curso mediante a regulação de 0 a 30 mm.
 Sélectionner la 1ère course par le curseur de 0 à 30 mm.

Installation Guidelines

Consejos de Instalación · Richtlinien zur Installation · Consigli di Installazione · Instruções de Instalação · Mode d'Installation

