

UNIT DATE STAMP

ES Fichador Unitario DE Datumstellereinheit
IT Datario Unitario PT Datador Unitário FR Kit Mini Dateur

● Cad Insertion Point

FU+ IU

TRACEABILITY



Patented

Max. 150°C

FU

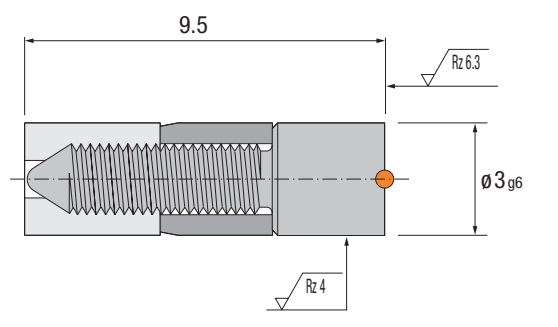
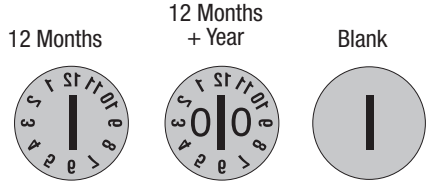

Supplied also with **UM** / Entregado también con el **UM** / UM im Lieferumfang enthalten
Fornito con il particolare **UM** / Também fornecido como **UM** / Fournis avec unité de montage **UM**

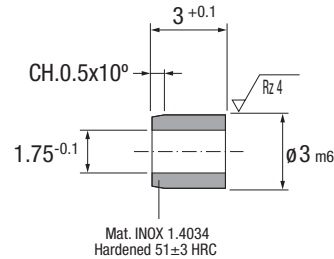
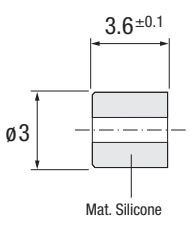

IU

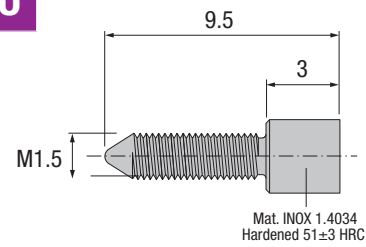

Only replacements / Sólo recambios / Nur Einsatz
Solo ricambi / Apenas substituições / Insert seulement

12 Months	12 Months+Year	Blank
FU.0310SF	FU.031012-..	FU.031000
IU.0310SF	IU.031095-..	IU.031000

IMPORTANT!
Indicate the year after the reference.
Indicar el año después de la referencia.
Geben Sie das Jahr nach dem Verweis an.
Indicare l'anno dopo il codice.
Indicar o ano depois da referência.
Indiquer l'année après la référence.

Installation Guidelines

Consejos de Instalación · Richtlinien zur Installation · Consigli di Installazione · Instruções de Instalação · Mode d'Installation

Engrave on the mould.
ES Grabar en el molde.
DE Gravur an der Form.
IT Incidere sullo stampo.
PT Gravar no molde.
FR Gravure sur le moule.

Year change.
ES Cambio de año.
DE Jahreswechsel.
IT Cambio dell'anno.
PT Mudança de ano.
FR Changement de l'année.

